

6000 TWIN LIFT Stepstool



- Reach for the sky

Tolerates heavy use without losing its looks:

- Dent proof
- Scratch proof
- Rust proof

Mobile on spring loaded castors that retract when weight is applied

Design:
Paul B. Buch

Capacity: 150 kg

Colours:

2 Year Warranty

6000-1 Black (RAL 9005) 6000-4 Red (RAL 3020)
6000-5 Blue (RAL 5005) 6000-9 Grey (RAL 7035)

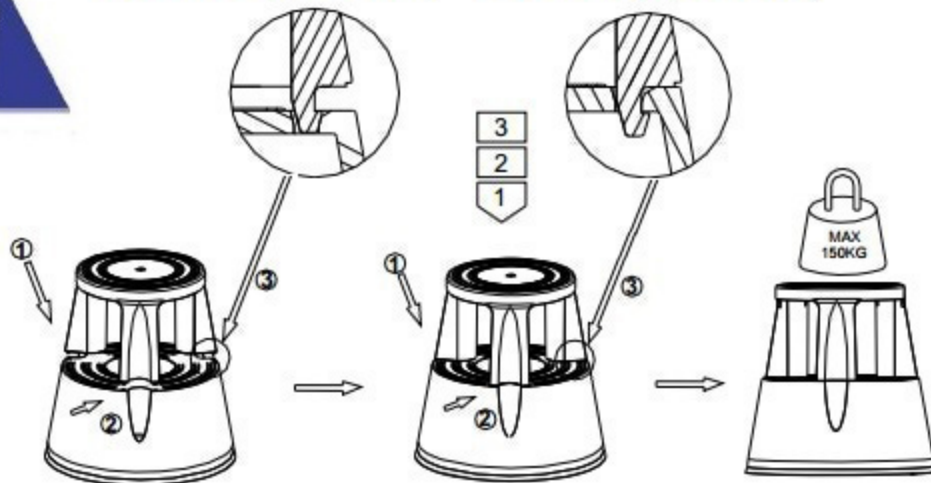
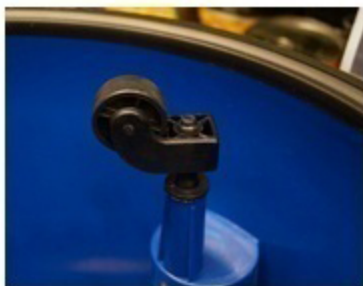

Logistics
EAN Code

Item No.	Product	Barcode	Customs tariff No.
6000-1	TWIN LIFT Stepstool	5708950 600015	94037090
6000-4	TWIN LIFT Stepstool	5708950 600046	94037090
6000-5	TWIN LIFT Stepstool	5708950 600053	94037090
6000-9	TWIN LIFT Stepstool	5708950 600091	94037090



Pallet

Item No.	Gross weight	Net weight	Tara (KG)	M ³	H x L x B (M)	Units per pallet	Pallet height (M)
6000	2,50	2,15	0,35	0,0453	0,23x0,45x0,45	48	1,99