



ENGLISH FRANÇAIS DEUTSCH NEDERLANDS
ITALIANO PORTUGUÊS ESPAÑOL ΕΛΛΗΝΙΚΗ



Getting Started 1

Démarrage 1

Inbetriebnahme 1

Aan de Slag-gids 1

Guida Rapida 1

Para Começar 1

Guía de inicio 1

Ξεκινώντας 1



Video Tutorials
Didacticiels vidéo
Videolernprogramme
Videozelfstudies

Tutorial video
Tutoriais em Vídeo
Tutoriales en vídeo
Βίντεο με οδηγίες

<http://canon.com/ijsetup>



RMC (Regulatory Model Code): K10437
RMC (Regulatory Model Code): K10436
RMC (Regulatory Model Code): K10435

1

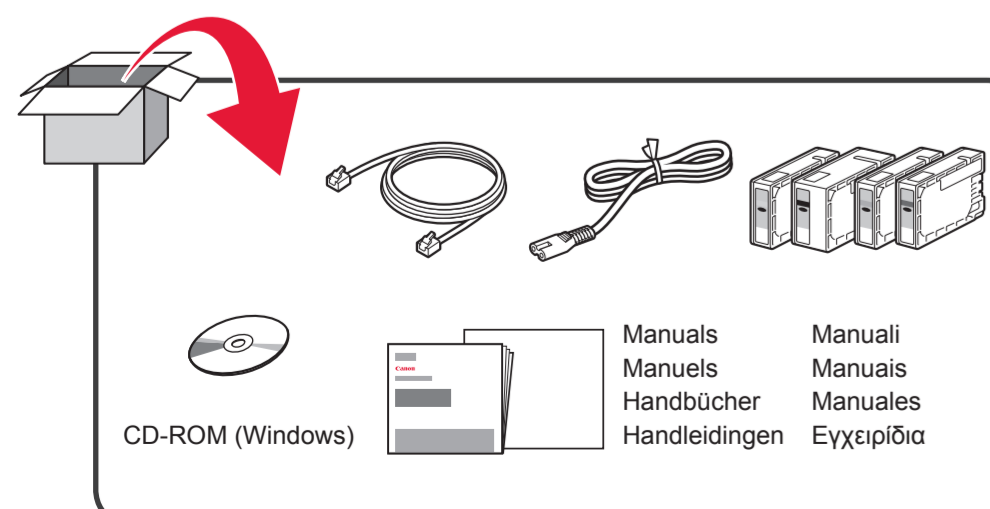

2

1 Remove the tape and packing materials from outside the printer.
Retirez la bande ainsi que les matériaux d'emballage de l'imprimante.
Entfernen Sie das Klebeband und das Verpackungsmaterial außen am Drucker.
Verwijder de tape en het verpakkingsmateriaal van de buitenkant van de printer.
Rimuovere il nastro e il materiale di imballaggio dall'esterno della stampante.
Remova a fita e os materiais de embalagem da parte externa da impressora.
Retire la cinta y los materiales de protección del exterior de la impresora.
Αφαιρέστε την ταινία και τη συσκευασία από τον εκτυπωτή.

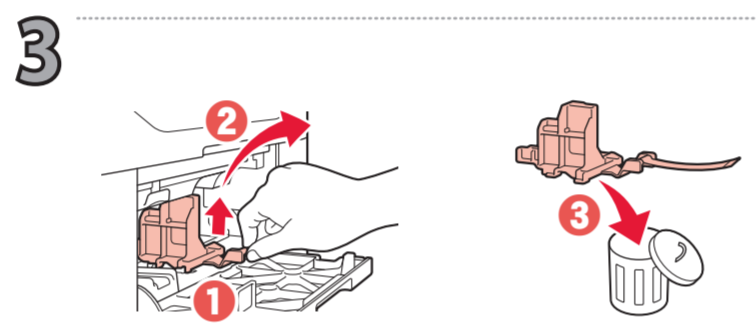
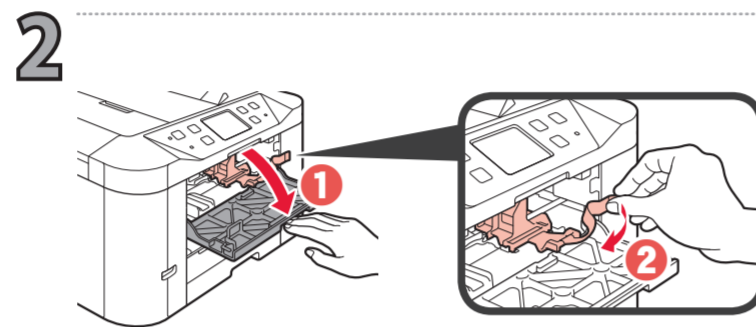

3

1 Back
Arrière
Rückseite
Achterkant

Retro
Parte traseira
Parte posterior
Πίσω μέρος

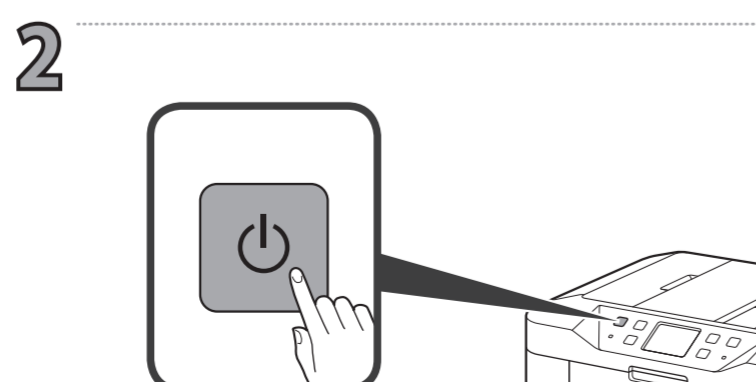
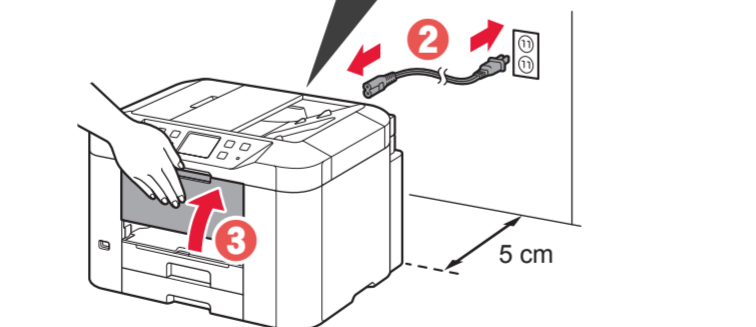
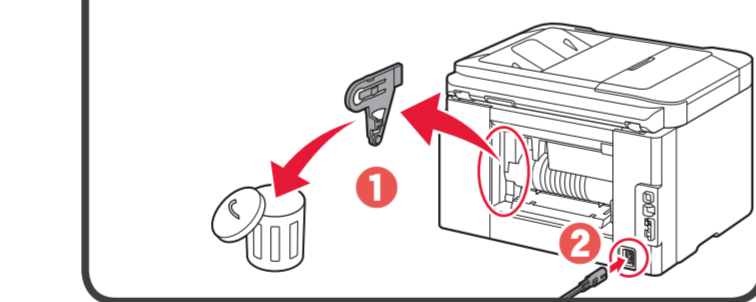

3

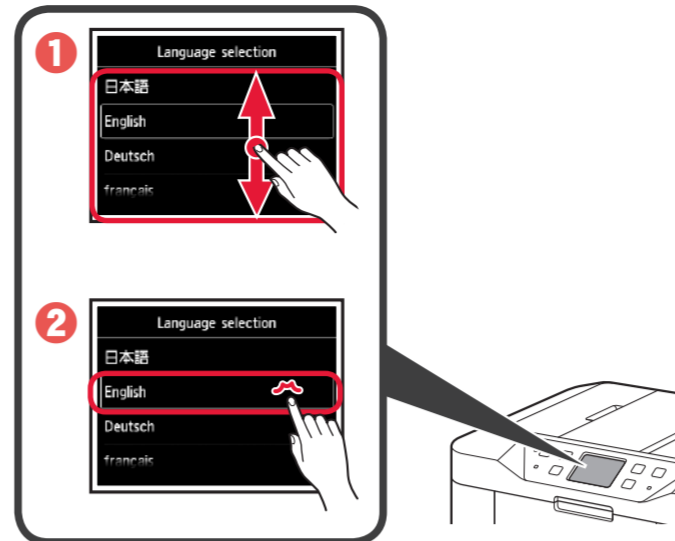

4 If the screens below appear, select your country or region.
Si les écrans ci-dessous s'affichent, sélectionnez votre pays ou votre région.
Wenn die folgenden Bildschirme angezeigt werden, wählen Sie Ihr Land oder Ihre Region aus.
Selecteer uw land of regio wanneer de onderstaande schermen worden weergegeven.
Se appare la schermata riportata di seguito, selezionare il paese o la regione.
Se as telas abaixo aparecerem, selecione seu país ou região.
Si aparecen las siguientes pantallas, seleccione su país o región.
Αν εμφανιστούν οι ακόλουθες οθόνες, επιλέξτε τη χώρα ή την περιοχή σας.

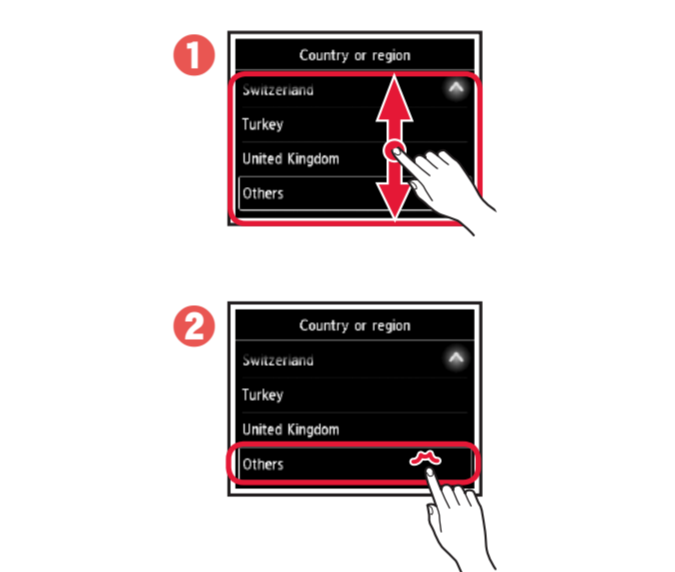

5 For development and marketing of products that better meet customer needs, Canon requests that information related to your Canon product be sent to Canon through the Internet.
Read the descriptions in the supplied "Safety and Important Information" and select whether you agree to send information.

Next

Agree
Do not agree

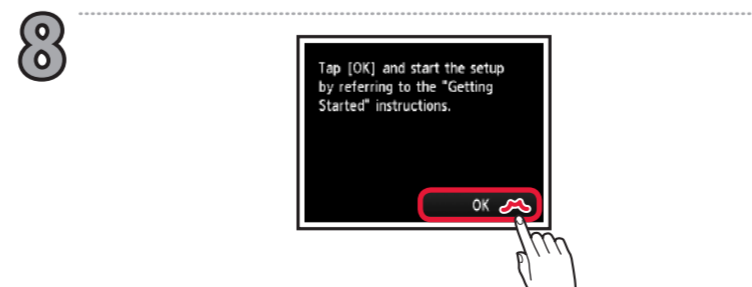
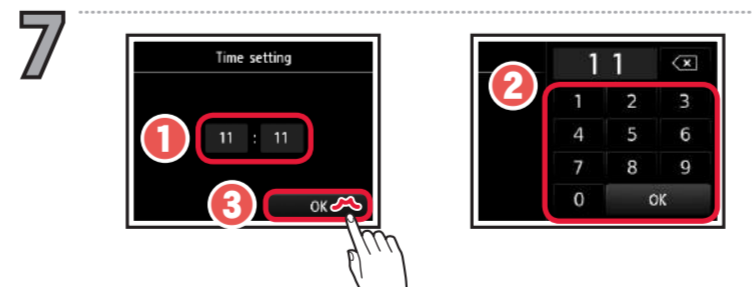
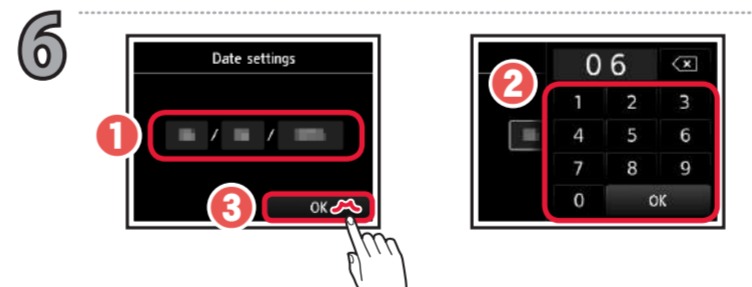

4

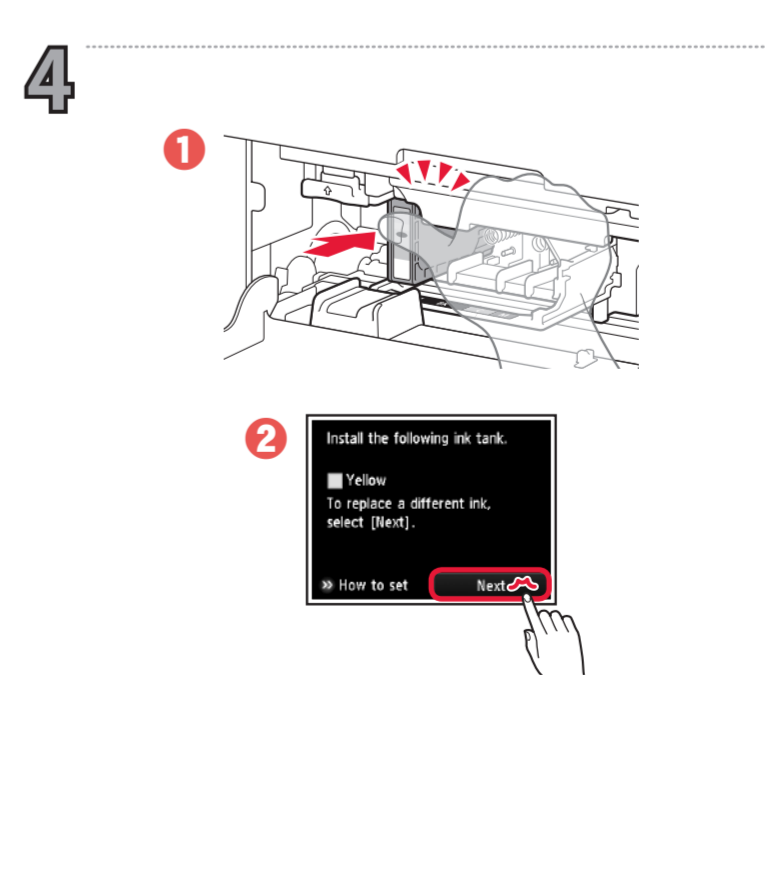
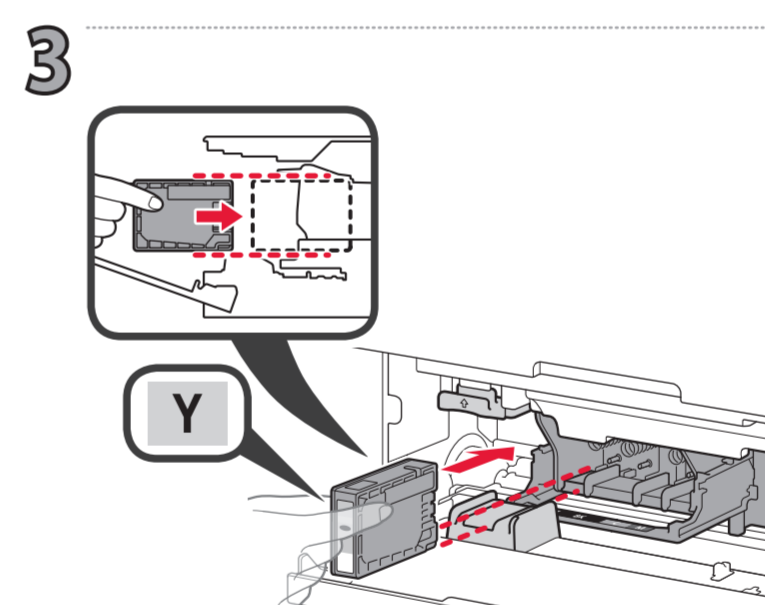
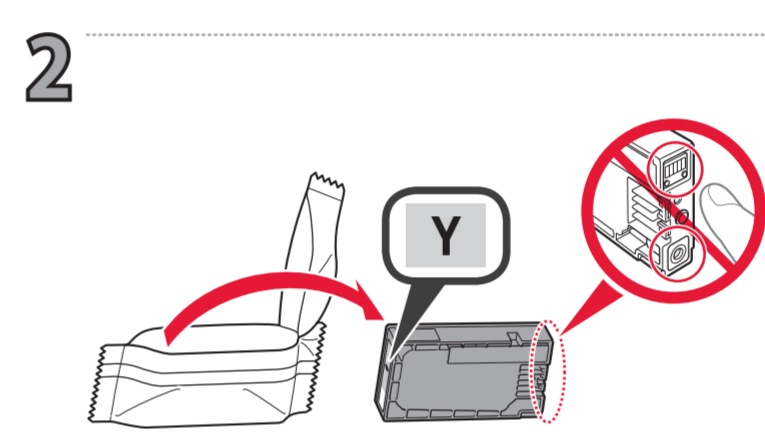
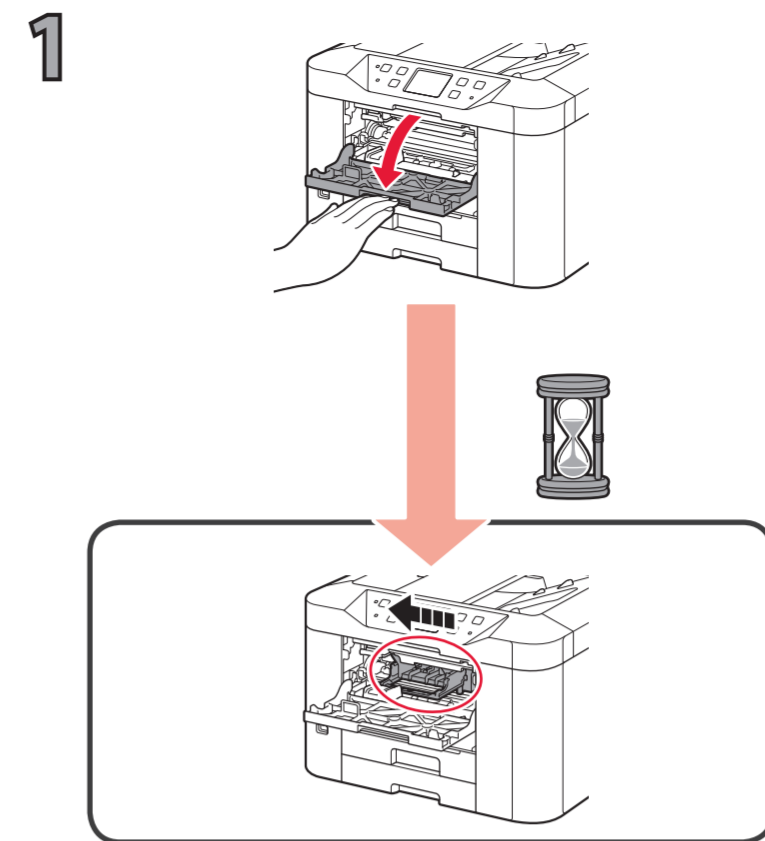

5

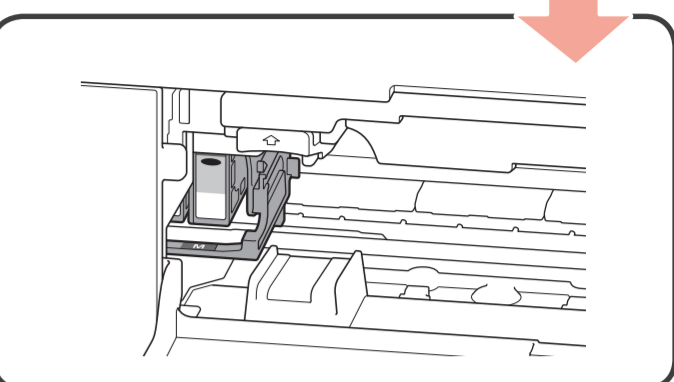
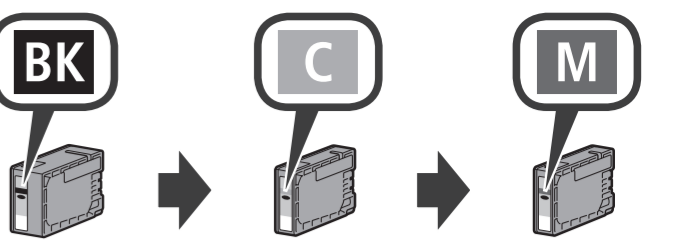

An installed ink tank cannot be removed until the message to replace it is displayed.

Une cartouche d'encre installée ne peut pas être retirée tant que le message demandant son remplacement n'est pas affiché.

Ein eingesetzter Tintenbehälter kann erst entfernt werden, wenn die entsprechende Meldung zu dessen Austausch angezeigt wird.

Een geïnstalleerde inktank kan pas worden verwijderd wanneer het bericht over vervanging wordt weergegeven.

Un serbatoio d'inchiostro installato non può essere rimosso finché non viene visualizzato il messaggio che indica di sostituirlo.

Um cartucho de tinta instalado não poderá ser removido antes da exibição da mensagem para substituí-lo.

Un depósito de tinta instalado no se puede retirar hasta que aparece el mensaje para retirarlo.

Δεν μπορείτε να αφαιρέσετε ένα τοποθετημένο δοχείο μελάνης μέχρι να εμφανιστεί στην οθόνη το μήνυμα αντικατάστασης.

6



5

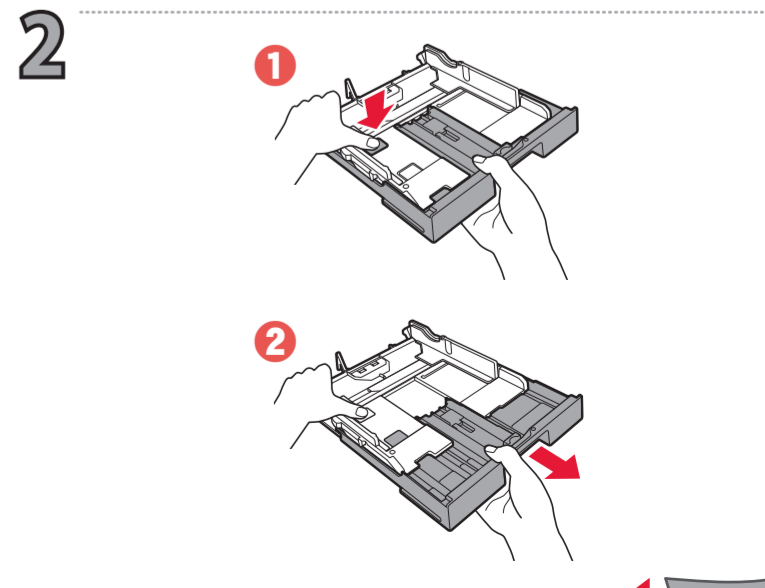
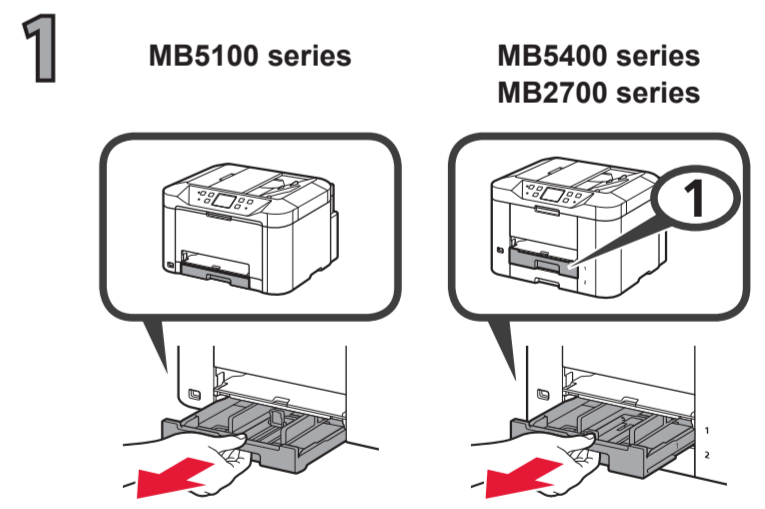

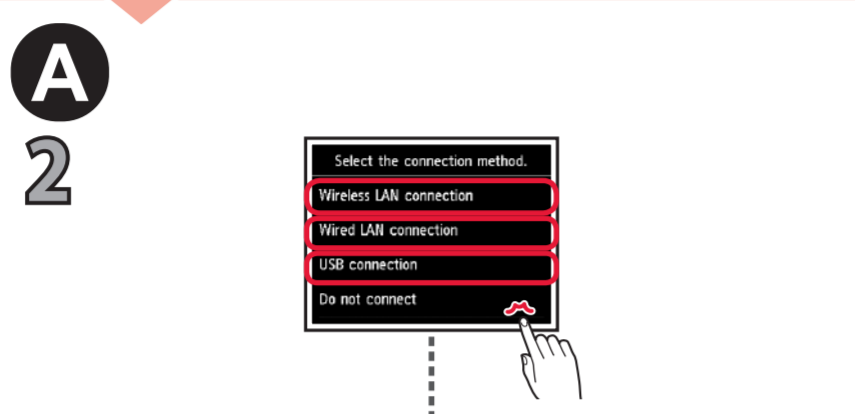
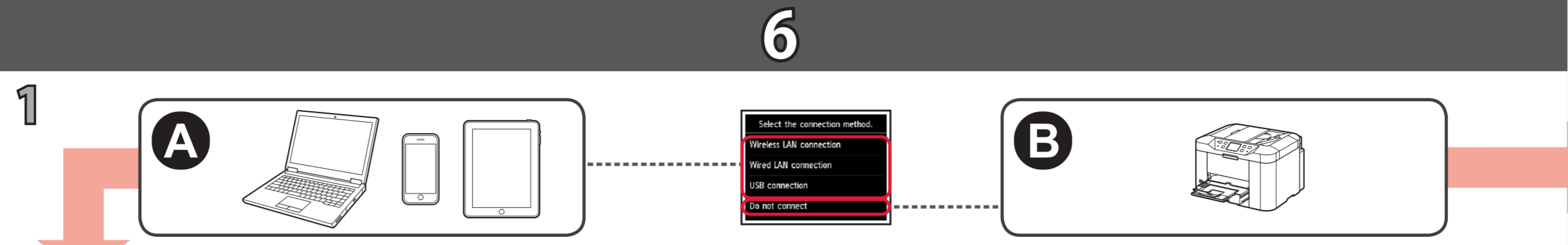
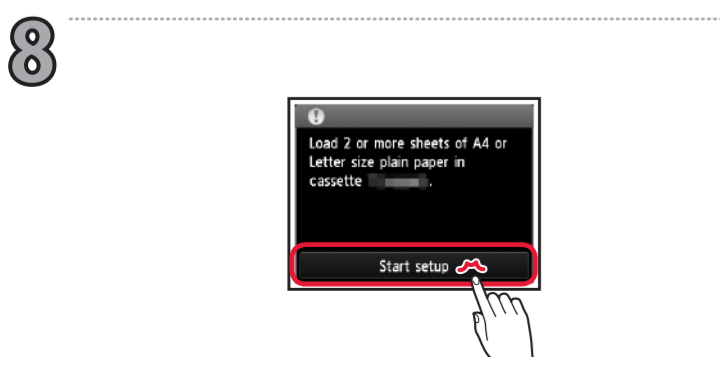
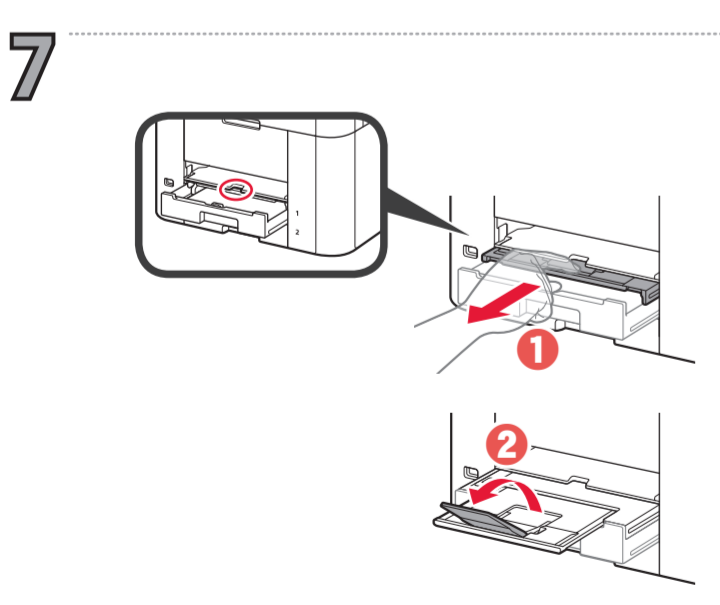
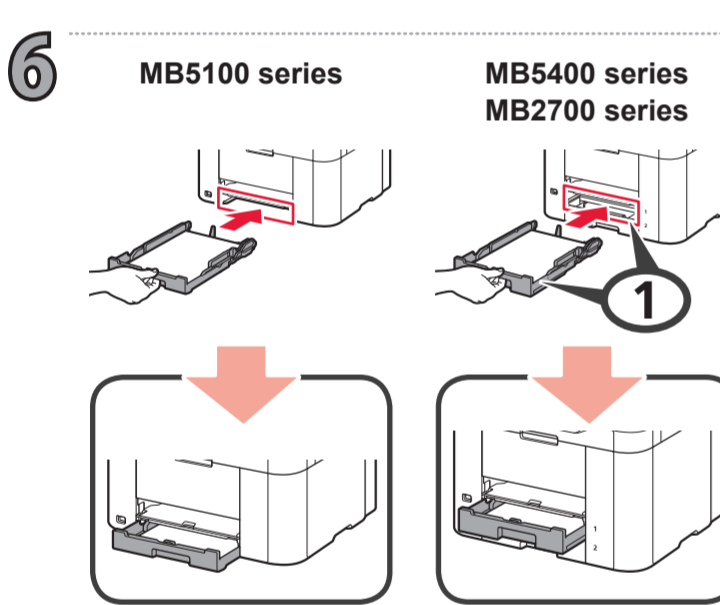
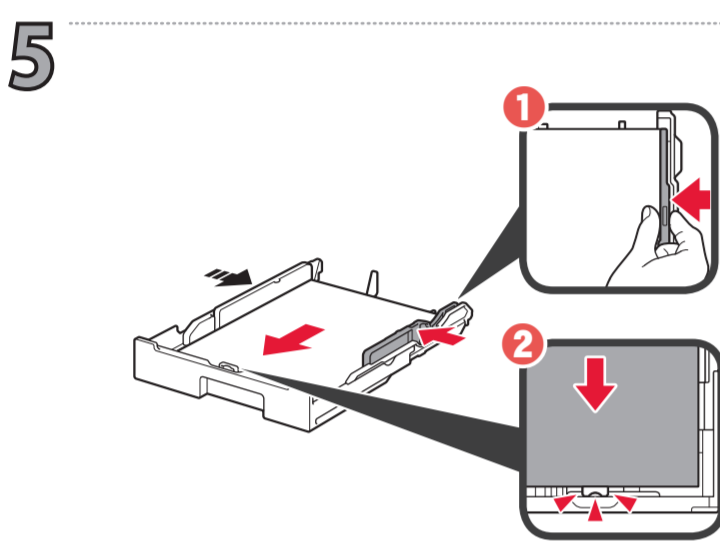
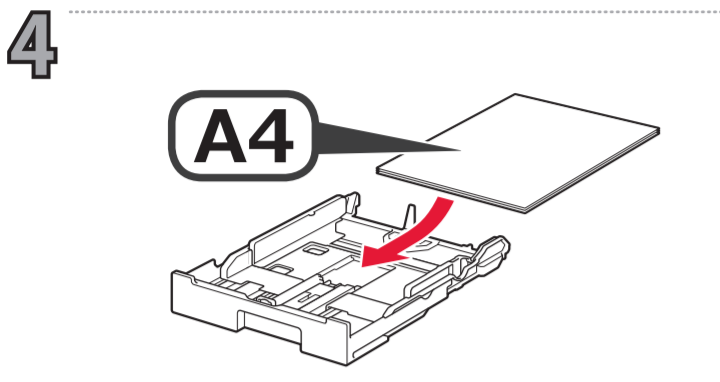
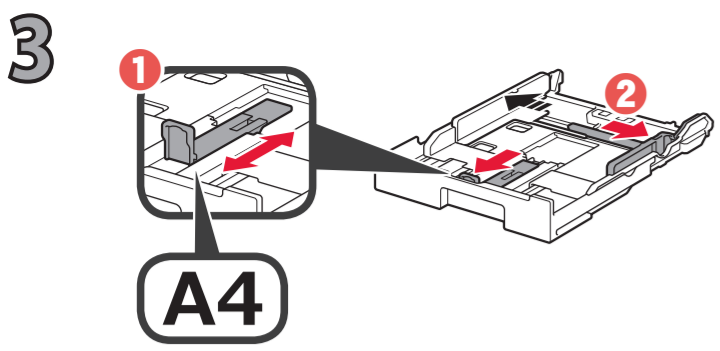

Connection method	Metodo di connessione
Méthode de connexion	Método de conexão
Verbindungsmethode	Método de conexión
Verbindungsmethode	Μέθοδος σύνδεσης

<p>Wireless LAN Réseau sans fil WLAN Draadloos LAN LAN wireless LAN Sem-fio LAN inalámbrica Ασύρματο LAN</p>	<p>Wired LAN Réseau câblé Drahtgebundenes LAN Bedraad LAN LAN wired LAN com fio LAN cableada Ενσύρματο LAN</p>
<p>USB</p>	

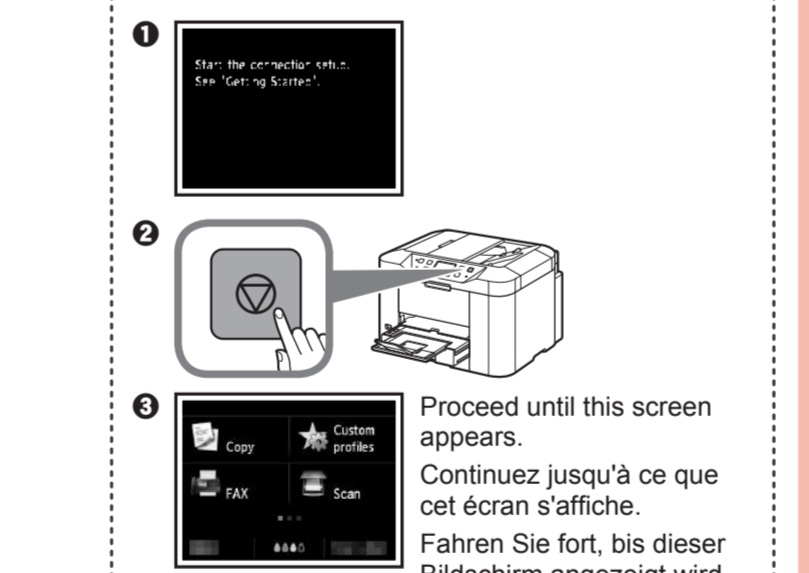
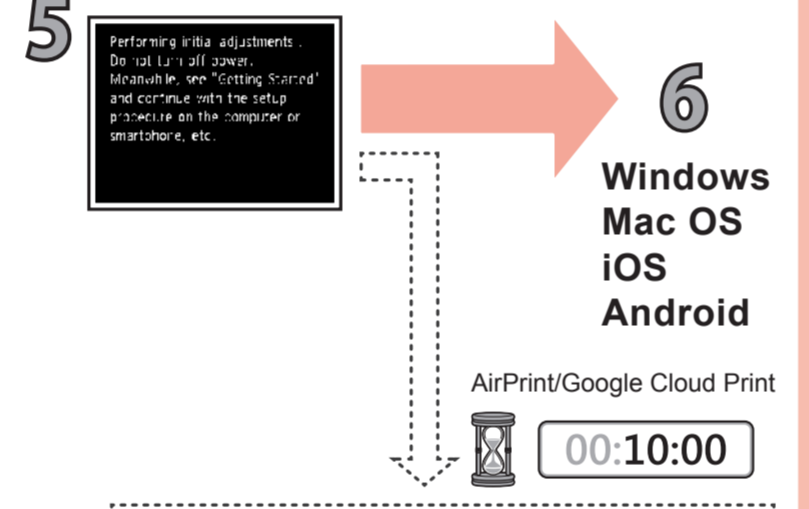
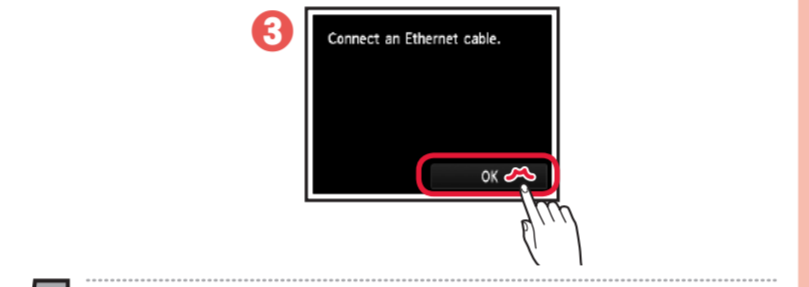
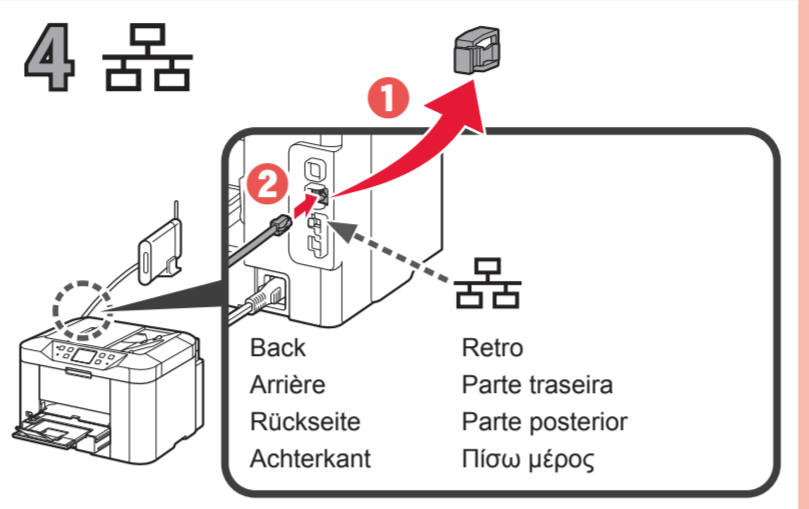
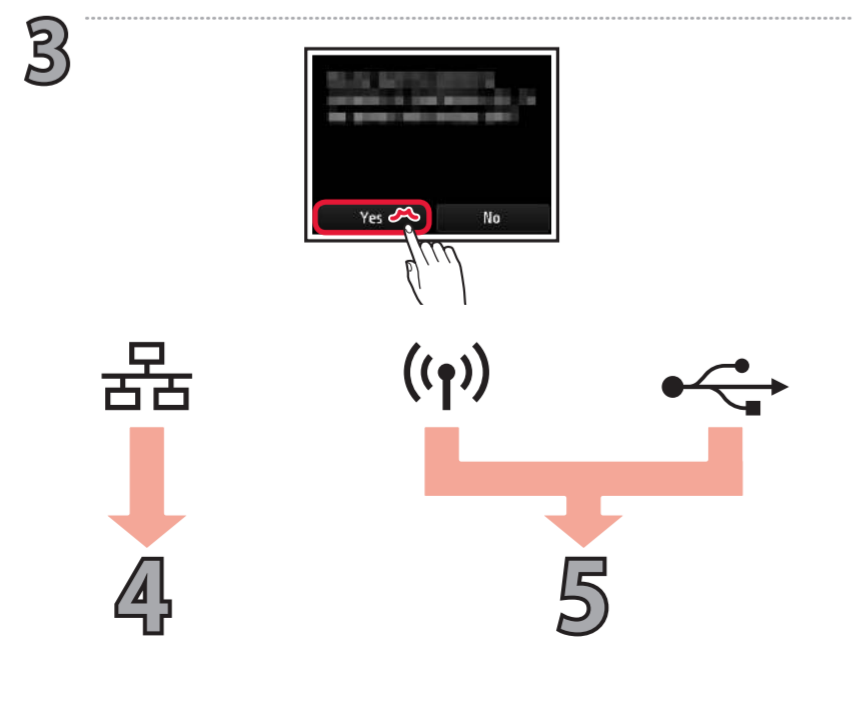

6 Follow the steps in the **Getting Started 2** to make connections and install software, and then continue the printer setup.
 Suivez les étapes du document **Démarrage 2** pour procéder aux connexions et installer le logiciel, puis continuez la configuration de l'imprimante.
 Befolgen Sie die Anweisungen unter **Inbetriebnahme 2**, um die Verbindungen herzustellen und die Software zu installieren, und fahren Sie dann mit der Einrichtung des Druckers fort.
 Volg de stappen in de **Aan de Slag-gids 2** om verbinding te maken en software te installeren en ga daarna verder met de installatie van de printer.
 Attenersi ai passaggi descritti nella **Guida Rapida 2** per effettuare le connessioni e installare il software, quindi continuare l'impostazione della stampante.
 Siga as etapas em **Para Começar 2** para fazer conexões e instalar o software e então prossiga com a configuração da impressora.
 Siga los pasos de la **Guía de inicio 2** para realizar las conexiones e instalar el software y después continúe con la configuración de la impresora.
 Για συνδέσεις και για εγκατάσταση λογισμικού, ακολουθήστε τα βήματα στο **Ξεκινώντας 2** και, έπειτα, συνεχίστε τη ρύθμιση του εκτυπωτή.

Getting Started 2
Démarrage 2
Inbetriebnahme 2
Aan de Slag-gids 2
Para Começar 2
Guía de inicio 2
Ξεκινώντας 2

How to set up the FAX
Configuration du FAX
Anweisungen zum Einrichten des FAX
De fax instellen
Guida alla configurazione del FAX
Como configurar o FAX
Cómo configurar el FAX
Ρύθμιση του FAX

<http://canon.com/ijsetup>

Installed Basic Manual
 Manuel de base installé
 Installiertes Basishandbuch
 Geïnstalleerde Basis Handleiding
 Installato Manuale di base
 Manual Básico Instalado
 Manual básico instalado
 Το Εγχειρίδιο Βασικών Λειτουργιών έχει εγκατασταθεί

B

2

1 Select the connection method.
 Wireless LAN connection
 Wired LAN connection
 USB connection
 Do not connect

2 Connection will not be set up. OK?
 Yes No

3

Adjusting...
 About 10 minutes

00:10:00

The printer is set up and ready for use.
 L'imprimante est configurée et prête à l'utilisation.
 Der Drucker ist eingerichtet und zur Verwendung bereit.
 De printer is ingesteld en gereed voor gebruik.
 La stampante è configurata e pronta per l'uso.
 A impressora é configurada e está pronta para uso.
 La impresora se ha configurado y está lista para su uso.
 Ο εκτυπωτής έχει ρυθμιστεί και είναι έτοιμος για χρήση.

?

The **Online Manual** is accessible from the website.
 Le **Manuel en ligne** est accessible à partir du site Web.
 Das **Online-Handbuch** finden Sie auf der Website.
 De **Online handleiding** is toegankelijk via de website.
 È possibile accedere al **Manuale online** dal sito Web.
 O **Manual On-line** pode ser acessado do site.
 Se puede acceder al **Manual en línea** desde el sitio web.
 Το **Εγχειρίδιο Online** διατίθεται στη διαδικτυακή τοποθεσία.

<http://canon.com/ijsetup>

Windows PC