

**Target market :**

90L plastic movable waste bin with pedal, ideal for all food spaces.

**Product features :**

- ❖ High-density virgin polyethylene
- ❖ Stainless steel rod assembly AISI 304 (18/10)
- ❖ Wide pedal
- ❖ Integrated handle
- ❖ HACCP approved
- ❖ Ideal to collect and sort waste



Produit contribuant à la Collecte Sélective des déchets

**Colour : White**



**Dimensions :**

Unit of Sale :

- Weight : 5.90kg
- Volume : 0,233m<sup>3</sup>
- Dim. (L\*W\*H) : 510\*510\*895

Pack :

- Weight : 7.64kg
- Volume : 0,256m<sup>3</sup>
- Dim (L\*W\*H) : 520\*550\*895

**Custom code :** 39 23 30 90

**Barcode :** 3019920567002

**Advantages :**

- ❖ Easy to clean
- ❖ Anti-corrosion and very strong
- ❖ Simple to move and empty

**Palletization :**

<b>Pallet quantity</b>	8
<b>Pallet height (m)</b>	2.34
<b>Number of products by layer</b>	2
<b>Number of layers</b>	4
<b>Pallet size (mm)</b>	1200/1000
<b>Pallet weight (kg)</b>	71

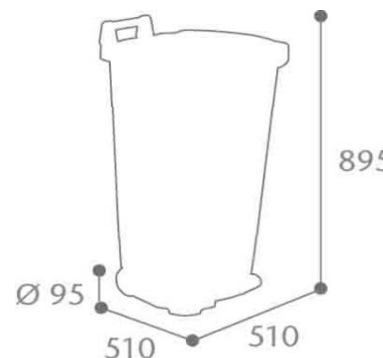

**Suggested catalogue text :**

*A plastic movable waste bin with pedal for hygienic waste disposal. Extremely practical and strong product. Perfect protection against cleaning products and humidity from the ground. Easy to clean thanks to rounded edges and large opening. Suitable for HACCP food standards & all medical/kitchen environments.*

*Overall dimensions : 510 x 510 H 895 mm – Capacity: 90 L – High-density virgin polyethylene.*