

FRIXION point 05

BL-FRP5 Specifications

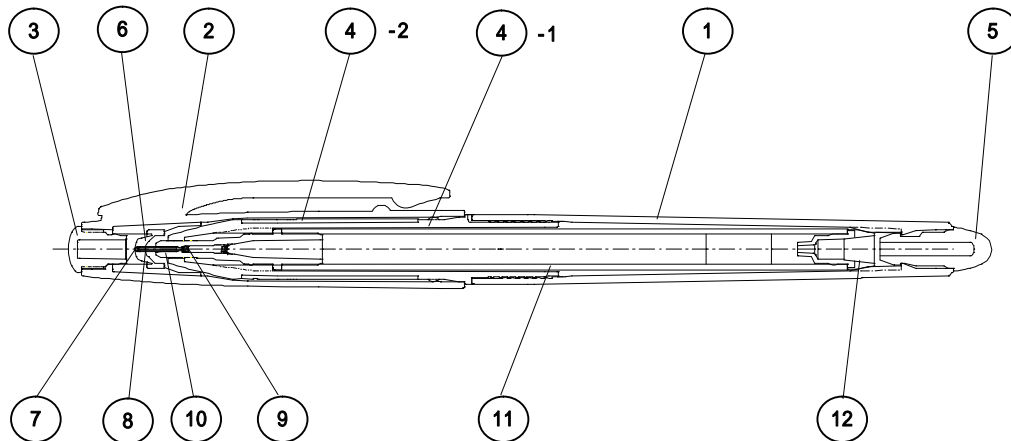

<Parts and Materials>

No.	Parts	Materials	Remarks
1	Barrel	Polycarbonate	Ink colour (Semitransparent)
2	Cap	Polycarbonate	Ink colour (Semitransparent)
3	Top Plug	Acrylonitrile butadiene styrene	Ink colour
4-1	Neck	Polycarbonate	Ink colour (Semitransparent)
4-2	Grip	Elastomer	Ink colour (Semitransparent)
5	Friction Eraser	Elastomer	Semitransparent
6	Rubber Seal	EPDM	Ink colour
7	Ball	Tungsten carbide alloy	φ0.5mm
8	Tip	Stainless steel	
9	Coil Spring	Stainless steel	
10	Tip Holder	Polypropylene	Ink colour
11	Refill Pipe	Polypropylene	Ink colour
12	Refill Tail Plug	Polypropylene	Ink colour
13	Ink (7 colours)	Water based "FRIXION" ink	Black, Red, Blue, Green, Violet, LightBlue, Pink
14	Ink Follower	Grease	

<Performance>

Ball Dia.	0.5mm
Write-out Distance	[Target] 350m
Width of Stroke	[Target] 0.25mm

<Wide Memory FRIXION Ink>

Ink colours	disappear at the temperature around 60
	start recovering at the temperature around -10
	completely recover at the temperature around -20